

## AUTOMATIC FINISH

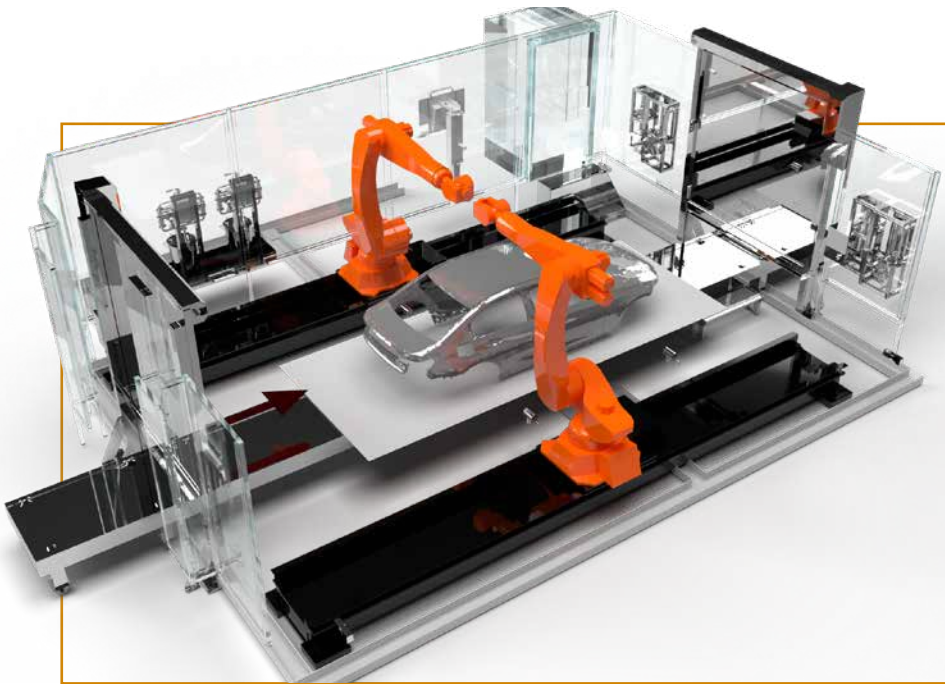

Automatic surface treatment after top coat and clear coat application

### Advantages

- High precision & fully automatic reworking process system in the paint finish
- Applied in top coat and in cathodic dipping coating (CDC)
- Repetability of process results
- Automatic allocation of application parameters and reworking processes depending on the type of defect
- Automated path planning of application programs

## PROCESS

### 1. Autom. Surface Inspection (ASI)

- Automatic defect detection

### 2. Automatic Sanding System

- Application of sanding paste
- Sanding
- Autom. abrasive change

### 3. Automatic Polishing System

- Application of polishing paste
- Polishing
- Autom. polishing sponge change

## PRODUCTS

### Changing Station for Abrasives and Polishing Sponges

- Secure and fast automatic change
- Zero production disruption
- Modular setup



Example measuring system

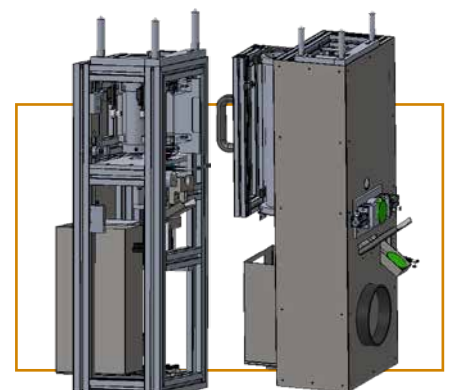

2008V1